

STEELHEART®

# UNDERCOUNTERS & PREP TABLES



# HOSHIZAKI

[hoshizakiamerica.com](http://hoshizakiamerica.com)



# HOSHIZAKI

## STEELHEART® | REFRIGERATION KEY FEATURES

The **Hoshizaki Steelheart® Refrigeration Series** is engineered to meet the tough demands of commercial kitchens. This series of upright refrigerators offers rugged, all-stainless steel construction inside and out for the best in durability, performance and efficiency.



**SUPERIOR**  
Refrigeration Performance



**DURABLE,**  
Sustainable Construction



**SIMPLE**  
Operation and Maintenance





# HOSHIZAKI

## STEELHEART® | UNDERCOUNTER PREP KEY FEATURE COMPARISON

FEATURE	<b>HOSHIZAKI</b> Steelheart® Series UR48B-D2	<b>TRAUlsen</b> UHT48-LR	<b>TRUE</b> TUC-48D-2-HC	<b>VICTORY</b> TUC-48D-2-HC	<b>BEVERAGE AIR</b> UCRD48AHC-2	<b>CONTINENTAL</b> SW60N16	<b>TURBO AIR</b> TST-60SD-N-CL
<b>Stainless Steel Exterior</b>	✓	✓	✓	✓	✓	✓	✓
<b>Stainless Steel Interior</b>	✓	Aluminum	Aluminum	Aluminum	Aluminum	✓	✓
<b>Temp Range</b>	<b>32°F To 38°F</b>	34°F To 38°F	33°F to 38°F	36°F to 38°F	36°F to 38°F	40°F	33°F To 38°F
<b>Refrigerant</b>	<b>R290</b>	R450	R450	R290	R290	R290	R290
<b>Evaporator Defrost</b>	<b>Adaptive defrost with hot gas</b>	Adaptive defrost	Off cycle defrost	Adaptive defrost	Adaptive defrost	Adaptive defrost with hot gas	Adaptive defrost
<b>Self-Closing / Stay-Open Doors</b>	✓	✓	✓	✓	✓	Self closing only	Self closing only
<b>Field Reversible Doors</b>	✓	N/A	N/A	N/A	N/A	✓	N/A
<b>Holds 6" Deep Pans</b>	✓	N/A	✓	✓	Top drawer – 6" Lower drawer – 4"	N/A	✓
<b>Clearance Requirement</b>	<b>1" Rear</b>	N/A	1" Rear	2" Rear	2" Rear	8" Rear and 3" Sides	2" Rear
<b>Warranty</b>	<b>7 Years compressor; 6 Years parts; 5 Years labor.</b>	5 Years compressor; 3 Years parts and labor.	7 Years compressor; 6 Years parts; 5 Years labor.	4 Years compressor; 3 Years parts and labor.	2 Years compressor; 3 Years parts and labor.	4 Years compressor; 3 Years parts and labor.	4 Years compressor; 3 Years parts and labor.



# HOSHIZAKI

STEELHEART® | REFRIGERATION  
SUPERIOR REFRIGERATION PERFORMANCE

**R290 hydrocarbon refrigerant**, combined with Hoshizaki's unique, ducted airflow technology, ensures that your food products remain fresh, nutritious, and safe.



Hoshizaki's exclusive design distributes cold air through a system of louvered ducts positioned throughout the cabinet.

Constant air movement circulates top to bottom and at each individual shelf to surround food with uniform cool temperatures.

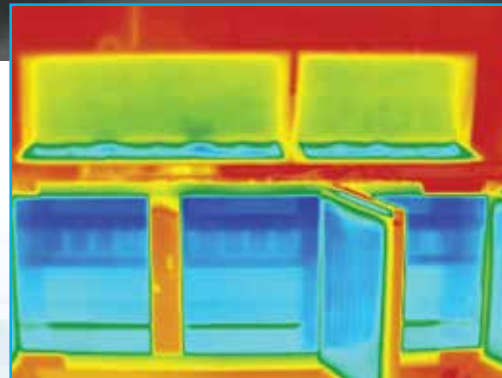

Engineered to maintain  
NSF-7 temperatures  
in 100°F ambient.  
Certified to NSF-7 temperatures  
in 86°F ambient.



# HOSHIZAKI

STEELHEART® | REFRIGERATION  
**DURABLE, SUSTAINABLE CONSTRUCTION**



### **Space Saving Design**

Designed with front breathing ventilation, our compact units require zero clearance at sides and rear

### **Durable & Convenient Door Features**

- ▶ Exclusive “stepped” design protects the door gasket
- ▶ Field reversible doors are easy to convert without a kit
- ▶ Spring hinge will self-close or stay open at 90° for ease of access

### **Energy Efficient**

- ▶ R290 Hydrocarbon refrigerant is environmentally friendly
- ▶ 2” foam insulation throughout the cabinet and doors means a more energy efficient unit

### **Solid Construction**

- ▶ Stainless steel exterior is clean, durable and corrosion resistant
- ▶ Stainless steel interior walls & floor with coved corners are easy to clean

### **Pan Rail and Cutting Boards**

Rails accommodate up to 6” deep pans and are provided with a full complement of plastic 1/6<sup>th</sup> size pans – 4” deep, adapter bars, prep guard and cutting board.

Megatop refrigerators have an extended top for better durability & support of cutting board.







# HOSHIZAKI

## STEELHEART® | SANDWICH PREP KEY FEATURE COMPARISON

FEATURE	HOSHIZAKI Steelheart® Series	TRAULSEN UPT Series	VICTORY VSP60HC-16	BEVERAGE AIR SPE60HC	TRUE TSSU-60-16-HC	CONTINENTAL SW60N16	RANDELL 9601-290	TURBO AIR TST-60SD-N-CL	DELFIELD Series D4460NP-12
<b>Stainless Steel Interior</b>	✓	Aluminum	Aluminum	Aluminum	Aluminum	Aluminum	Aluminum	✓	ABS
<b>Temp Range</b>	<b>32°F To 41°F</b>	34°F To 38°F	36°F to 38°F	36°F to 38°F	33°F to 41°F	33°F to 41°F	Undetermined	33°F To 39°F	36°F To 40°F
<b>Refrigerant</b>	<b>R290</b>	R450	R290	R290	R290	R290	R290	R290	R290
<b>Adaptive Defrost</b>	<b>Adaptive</b>	Adaptive	Adaptive	Adaptive	Adaptive	Off-Cycle Defrost	Adaptive	Adaptive	Off-Cycle De-frost
<b>Electronic Controller</b>	✓	✓	✓	✓	✓	✓	✓	Digital	✓
<b>Self-Closing Door within 80°F</b>	✓	✓	Stay open only	✓	✓	Self closing only	Self closing only	N/A	N/A
<b>Magnetic snap in gaskets</b>	✓	✓	✓	✓	✓	✓	✓	✓	✓
<b>Reversible Doors</b>	✓	N/A	N/A	✓	N/A	✓	N/A	N/A	N/A
<b>Clearance Requirement</b>	<b>1" Rear</b>	N/A	2" Rear	2" Rear	1" Rear	3" Sides and Rear with casters	1" Rear	1" Rear	N/A
<b>Warranty</b>	<b>7 Years compressor; 6 Years parts; 5 Years labor.</b>	5 Years compressor; 3 Years parts and labor.	4 Years compressor; 3 Years parts and labor.	4 Years compressor; 3 Years parts and labor.	7 Years compressor; 6 Years parts; 5 Years labor.	5 Years compressor; 3 Years parts and labor.	5 Years compressor; 1 Year parts; 9 months labor.	7 Years compressor; 5 Years parts and labor.	2 Years compressor; 3 Years parts and labor.



# HOSHIZAKI

STEELHEART® | REFRIGERATION  
SIMPLE OPERATION AND MAINTENANCE

## Electronic Controls (Rear mount refrigeration models)

- ▶ More precise temperature control helps keep food fresh longer.
- ▶ Delayed evaporator fan restart coming out of defrost prevents warm air from being distributed into the cabinet.
- ▶ Time delay on compressor during start up prolongs compressor life expectancy.

## LED Digital Display (PR & CR models only)

Solid state digital controls monitor the operation and performance of the refrigeration system. The controls also provide visual temperature and voltage alarms.



Energy efficient LED interior lights with on/off switch (glass door undercounter models only)

## ANSI, NSF, UL/ETL

Our products surpass the most stringent tests in the foodservice industry - our own! Each HOSHIZAKI refrigeration product must pass 24 quality performance test standards, is run tested on the line and approved by Quality Control before it can be sold.

HOSHIZAKI is an ENERGY STAR® Award winner since 2012.

- ▶ Partner of the year in 2013 & 2014
- ▶ Sustained Excellence Award winner in 2015 - 2023





# HOSHIZAKI

## STEELHEART® | REFRIGERATION CHEF BASES



CR36A



CR49A

HOSHIZAKI's integrated ceramic heat shield assures your food products are cool and safe during blazing hot cooking!

Our innovative technology helps you optimize your kitchen efficiency with a two-in-one chef base – extra-large top space for cooking equipment plus high performance, cold storage drawers. Made of heavy duty stainless steel, all drawers hold 6" deep pans that are easy to lift out. Available in 36"–110" width options.

- ▶ **Built-in ceramic heat shield protects food from high heat**
- ▶ **Stainless steel interior and exterior front, sides and top**
- ▶ **Heavy duty 16 gauge stainless steel top with maximum top surface area**
- ▶ **Solid state digital controller with temperature alarms and LED display (Fahrenheit or Celsius)**
- ▶ **Drawers will accommodate 6" deep pans**
- ▶ **90° side edges maximize top surface area and stability for cooking equipment. Marine edges on both front and back allow for easy cleaning.**





# HOSHIZAKI

## STEELHEART® | CHEF BASE KEY FEATURE COMPARISON

FEATURE	HOSHIZAKI Steelheart® CR60A	TRAULSEN TEO Series	TRUE TRCB Series	VICTORY CBR Series	BEVERAGE AIR WTRCS Series	CONTINENTAL D Series	TURBO AIR PRCBE Series
<b>Stainless Steel Structure</b>	✓	✓	✓	✓	✓	✓	✓
<b>Temp Range</b>	32°F To 52°F	34°F To 38°F	33°F to 38°F	36°F to 38°F	36°F to 38°F	Undetermined	33°F To 38°F
<b>Refrigerant</b>	R290	R450	R290	R290	R290	R290	R290
<b>Total Max Weight Capacity</b>	600 lbs.	1200 lbs.	717 lbs. (top weight only)	1000 lbs.	1000 lbs.	1000 lbs.	788 lbs. (top weight only)
<b>Evaporator Defrost</b>	Adaptive defrost with hot gas	Off cycle evaporator defrost	Off cycle evaporator defrost	Adaptive defrost with hot gas	Adaptive defrost with hot gas	Adaptive defrost with hot gas	Adaptive defrost with hot gas
<b>Edge Description</b>	Drip edge & marine edge	Drip guard & marine edge	Marine edge standard	Marine edge standard	Marine edge standard	Drip guard & marine edge	Drip guard & marine edge
<b>Heat Shield or Fireproof Top</b>	✓	N/A	N/A	✓	✓	As an accessory	✓
<b>Holds 6" Deep Pans</b>	✓	✓	4" Pan	✓	✓	✓	✓
<b>Clearance Requirement</b>	1" Rear Bumper, 1" Sides, 4" top	N/A	1" Rear Bumper, 4" Top	1" Rear	1" Rear	1" Rear, 3" Sides	5" Rear
<b>Warranty</b>	7 Years compressor; 6 Years parts; 5 Years labor.	5 Years compressor; 3 Years parts and labor.	7 Years compressor; 6 Years parts; 5 Years labor.	4 Years compressor; 3 Years parts and labor; 2 Years on gaskets; Lifetime on drawer parts.	4 Years compressor; 3 Years parts and labor; Lifetime on drawer parts.	2 Years compressor; 3 Years parts and labor.	7 Years compressor; 5 Years parts and labor.



# HOSHIZAKI

## STEELHEART® | REFRIGERATION FULL LINE OF EQUIPMENT OPTIONS



UNDERCOUNTER  
REFRIGERATORS  
& FREEZERS\*



GLASS DOOR  
UNDERCOUNTER  
REFRIGERATORS  
& FREEZERS



WORKTOP  
REFRIGERATORS  
& FREEZERS\*



REFRIGERATED  
CHEF BASE

SANDWICH TOP REFRIGERATORS\*

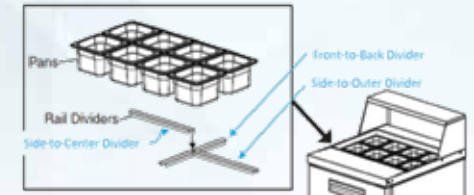

MEGA TOP REFRIGERATORS\*

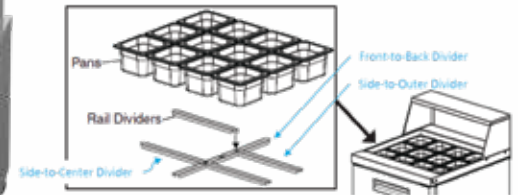

PIZZA PREP REFRIGERATORS\*

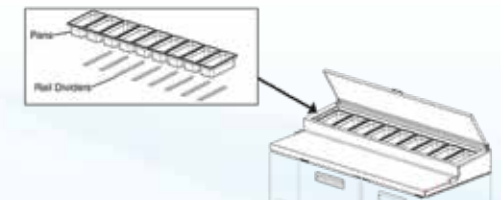

\*Drawer / Door combinations available.  
See Catalog & Price Guide for complete list.



# HOSHIZAKI

STEELHEART® | PIZZA PREPS  
FEATURES & BENEFITS

## PIZZA PREP TABLE MODELS

11 MODELS - INCLUDING 2 NEW 60-INCH OPTIONS



### Night/Day Mode

When lid is open, set point drops to keep food cool in rail; when lid is closed, set point returns to normal so food can stay in rail overnight without freezing.

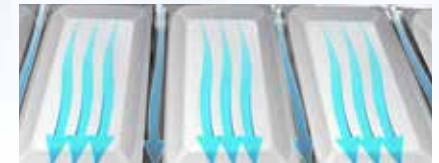

### Optimal Airflow in Rail

Back to front airflow surrounds each pan for consistent cooling.

### Removable Air Filter

Easy cleaning and better operation.



### Dual Controller System

For ideal temperature in both rail and cabinet; adjustable for every operation.





# HOSHIZAKI

## STEELHEART® | PIZZA PREP KEY FEATURE COMPARISON

FEATURE	HOSHIZAKI Steelheart® Series	TRUE TPP Series	BEVERAGE AIR DP Series	CONTINENTAL PA Series	TURBO AIR TPR Series	TRAULSEN TS Series	DELFIELD Series 1866OPTBMP
<b>Engineered to maintain NSF-7 temperatures in 100° F ambient</b> (Certified to NSF-7 temperatures in 86° F ambient)	✓		✓	✓			
<b>Stainless Steel Interior and Exterior</b>	✓		✓		✓	✓	
<b>Temp Range</b>	<b>32°F to 41°F</b>	33°F to 41°F	36°F to 38°F		33°F to 41°F	34°F to 38°F	33°F to 40°F
<b>Refrigerant</b>	<b>R290</b>	R290	R290	R290	R290	R290	R290
<b>Removable filter for easy cleaning</b>	✓	N/A	N/A	N/A	N/A	N/A	N/A
<b>Defrost</b>	<b>Adaptive</b>	Adaptive	Adaptive	Off Cycle	Adaptive	Adaptive	Adaptive
<b>Self closing / stay open feature</b>	✓	N/A	✓	N/A	N/A	✓	N/A
<b>Field reversible doors</b>	✓	N/A	✓	✓	N/A	N/A	N/A
<b>Dual controllers</b>	✓	N/A	N/A	N/A	N/A	N/A	N/A
<b>Clearance Requirement</b>	<b>1" Rear</b>	1" Rear	2" Rear	3" Front, Sides, Rear	1" Rear	✓	0
<b>Warranty</b>	<b>7 Years compressor; 6 Years parts; 5 Years labor.</b>	7 Years compressor; 6 Years parts; 5 Years labor.	5 Years compressor; 3 Years parts and labor.	5 Years compressor; 3 Years parts and labor.	5 Years compressor; 3 Years parts and labor.	5 Years compressor; 3 Years parts and labor.	2 Years compressor; 3 Years parts and labor.



# HOSHIZAKI

## STEELHEART® | REFRIGERATION PREP TABLES PAN CHART

SANDWICH TOP **REFRIGERATORS**



MEGA TOP **REFRIGERATORS**



PIZZA PREP **REFRIGERATORS**



PAN SIZE	FULL SIZE			2/3 SIZE			1/2 SIZE			1/2 SIZE LONG			1/3 SIZE			1/4 SIZE			1/6 SIZE			1/9 SIZE	
	12 3/4" x 20 3/4"			13 3/4" x 12 3/4"			12 3/4" x 10 3/8"			20 3/4" x 6 7/16"			12 3/4" x 6 7/8"			10 3/8" x 6 3/8"			6 7/8" x 6 1/4"			6 1/4" x 4 1/4"	
Pan Depth	2-1/2"	4"	6"	2-1/2"	4"	6"	2-1/2"	4"	6"	2-1/2"	4"	6"	2-1/2"	4"	6"	2-1/2"	4"	6"	2-1/2"	4"	6"	2-1/2"	4"
Cups	36	60	88	24	40	57	16	28	40	16	28	40	10.5	18	26	6.4	12	19	10.5	18	25	2.5	5
Quarts	9	15	22	6	10	14.25	4	7	10	4	7	10	2.6	4.5	6.5	1.6	3	4.75	2.6	4.5	6.5	.63	1.25

- Pans by others. Full complement of 1/16 size pans, 4" deep, and divider bars are included. Pan sizes are industry standard, but actual sizes may vary slightly by manufacturer.

### FULL SIZE PAN EQUIVALENCY CHART







# HOSHIZAKI

## STEELHEART® | REFRIGERATION SANDWICH PREP - Divider Bars & Pans



# HOSHIZAKI

## STEELHEART

### SANDWICH PREP TABLES FULL SIZE PAN RAIL CAPACITY

SR27_-8	(1) Full size* & (2) 1/9 size pans	SR48_-8 SR60_-8	(1) Full size & (1) 1/3 size pans	(1) Full size & (2) 1/6 size pans	(1) Full size & (3) 1/9 size pans	
	 *Requires HS-5280					
SR36_-10	(2) 2/3 size pans + (1) 1/3 size pan		SR48_-12 SR60_-12 SR72_-12	(2) Full size pans		
SR60_-16 SR72_-16	(2) Full size pans & (2) 1/3 size pans		(2) Full size pans & (4) 1/6 size pans		(2) Full size pans & (6) 1/9 size pans	
SR72_-18	(3) Full size pans					

PAN SIZE	FULL SIZE 12 3/4" x 20 3/4"			2/3 SIZE 13 3/4" x 12 3/4"			1/2 SIZE 12 3/4" x 10 3/8"			1/2 SIZE LONG 20 3/4" x 6 7/16"			1/3 SIZE 12 3/4" x 6 7/8"			1/4 SIZE 10 3/8" x 6 3/8"			1/6 SIZE 6 7/8" x 6 1/4"			1/9 SIZE 6 3/4" x 4 1/4"	
	2-1/2"	4"	6"	2-1/2"	4"	6"	2-1/2"	4"	6"	2-1/2"	4"	6"	2-1/2"	4"	6"	2-1/2"	4"	6"	2-1/2"	4"	6"	2-1/2"	4"
Pan Depth	2-1/2"	4"	6"	2-1/2"	4"	6"	2-1/2"	4"	6"	2-1/2"	4"	6"	2-1/2"	4"	6"	2-1/2"	4"	6"	2-1/2"	4"	6"	2-1/2"	4"
Cups	36	60	88	25	40	57	16	28	40	16	28	40	10.5	18	26	6.4	12	19	10.5	18	26	2.5	5
Quarts	9	15	22	6	10	14.25	4	7	10	4	7	10	2.6	4.5	6.5	1.6	3	4.75	2.6	4.5	6.5	0.63	1.25

Pans by others. Full complement of 1/3 size pans, 4" deep, and divider bars are included. Pan sizes are industry standard, but actual sizes may vary slightly by manufacturer.

FULL SIZE PAN EQUIVALENCY CHART



# HOSHIZAKI

## STEELHEART® | REFRIGERATION MEGA TOP PREP - Divider Bars & Pans

Center divider bars have notches to accept interlocking side divider bars.

- Provides stability for pan placement by preventing side bars from sliding out of position that could allow pans to fall into cabinet below.
- Increased flexibility for user because center notches allow user to easily re-configure bars to accept desired pan sizes for their unique menu.
- Made of high quality stainless steel insures long life.

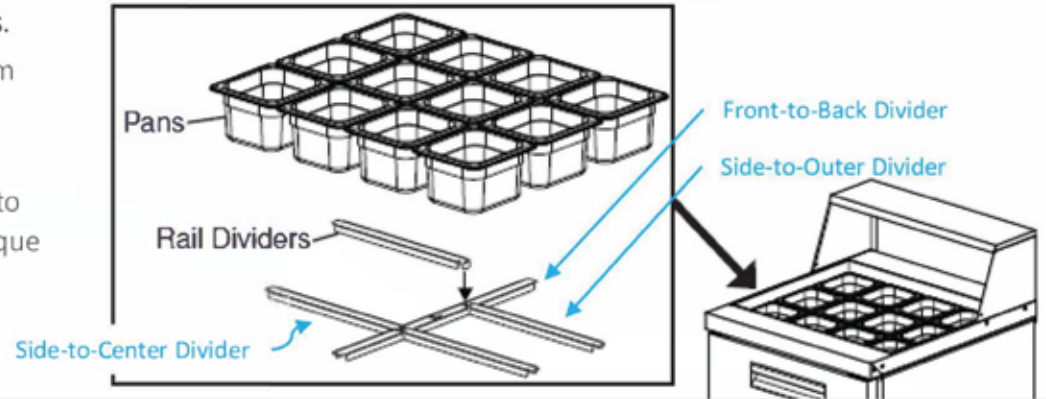

SR27B-12M, SR48B-12M, SR60B-12M

SR36B-15M

SR48B-18M, SR60B-18M, SR72B-18M



(2) Full size pans

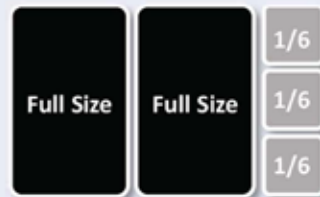

(2) Full size pans  
+ (3) 1/6 pans



(3) Full size pans

SR60B-24M, SR72B-24M

SR72B-30M

(4) Full size pans (2 per opening)



(5) Full size pans (3 in left opening, 2 in right opening)





# HOSHIZAKI









## STEELHEART® | REFRIGERATION PIZZA PREP - Divider Bars & Pans



# HOSHIZAKI



## PIZZA PREP TABLES RAIL PAN CAPACITY

<b>46"</b> WIDE MODELS	(6) 1/3 pans, maximum 6" deep  No additional divider bars required	(12) 1/6 pans, maximum 6" deep  No additional divider bars required	(18) 1/9 pans, maximum 6" deep  No additional divider bars required
	(8) 1/3 pans, maximum 6" deep  No additional divider bars required	(16) 1/6 pans, maximum 6" deep  No additional divider bars required	(24) 1/9 pans, maximum 6" deep  No additional divider bars required
	(9) 1/3 pans, maximum 6" deep  No additional divider bars required	(18) 1/6 pans, maximum 6" deep  No additional divider bars required	(27) 1/9 pans, maximum 6" deep  No additional divider bars required
	(12) 1/3 pans, maximum 6" deep  No additional divider bars required	(24) 1/6 pans, maximum 6" deep  No additional divider bars required	(36) 1/9 pans, maximum 6" deep  No additional divider bars required

PAN SIZE	FULL SIZE 12 3/4" x 20 3/4"			2/3 SIZE 13 3/4" x 12 3/4"			1/2 SIZE 12 3/4" x 10 3/8"			1/2 SIZE LONG 20 3/4" x 6 7/16"			1/3 SIZE 12 3/4" x 6 7/8"			1/4 SIZE 10 3/8" x 6 3/8"			1/6 SIZE 6 7/8" x 6 1/4"			1/9 SIZE 6 1/4" x 4 1/4"	
Pan Depth	2-1/2"	4"	6"	2-1/2"	4"	6"	2-1/2"	4"	6"	2-1/2"	4"	6"	2-1/2"	4"	6"	2-1/2"	4"	6"	2-1/2"	4"	6"	2-1/2"	4"
Cups	36	60	88	25	40	57	16	28	40	16	28	40	10.5	18	26	6.4	12	19	10.5	18	26	2.5	5
Quarts	9	15	22	6	10	14.25	4	7	10	4	7	10	2.6	4.5	6.5	1.6	3	4.75	2.6	4.5	6.5	0.63	1.25

Pans by others. Full complement of 1/3 size pans, 4" deep, and divider bars are included. Pan sizes are industry standard, but actual sizes may vary slightly by manufacturer.

FULL SIZE PAN EQUIVALENCY CHART



# HOSHIZAKI

## STEELHEART® | REFRIGERATION DRAWER DIVIDER BARS



# HOSHIZAKI



## HORIZONTAL REFRIGERATION DRAWERS DRAWER PAN CAPACITY

	27" & 60" Width		48" & 72" Width		
	TOP DRAWERS	BOTTOM DRAWERS	TOP DRAWERS	BOTTOM DRAWERS	
UNDERCOUNTERS WORKTOPS SANDWICH PREPS MEGA TOPS	(1) Full size & (2) 1/4 size pans  <i>Pan Orientation Requires HS-5433</i>	(1) Full size pan 	(1) Full size & (3) 1/9 size pans  <i>Pan Orientation Requires HS-5432</i>	(1) 1/2, (1) 1/3, (1) 1/4 & (1) 1/6 size pans 	(1) 1/2 & (1) 1/3 size pans 
CHEF BASES	36" Width (1) Full size & (3) 1/6 size pans per drawer  <b>x2 Drawers</b>	49" & 60" Width (2) Full size, (1) 1/3 & (1) 1/6 size pans per drawer  <b>x2 Drawers</b>	72" Width (2) Full size pans per drawer  <b>x4 Drawers</b>	85" Width (3) Full size pans per <i>left</i> drawers <b>x2 Drawers</b> (2) Full size pans per <i>right</i> drawers <b>x2 Drawers</b>	98" & 100" Width (3) Full size pans per drawer  <b>x4 Drawers</b>
	PIZZA PREP TABLES	46" Width (2) Full size pans per drawer <b>x2 Drawers</b>		67" Width (2) Full size pans per drawer <b>x4 Drawers</b>	

Drawers can accommodate 6" deep pans (except where noted in red). Drawer pans not included. Pans by others. Pan sizes are industry standard, but actual sizes may vary slightly by manufacturer.

FULL SIZE PAN EQUIVALENCY CHART



# HOSHIZAKI

STEELHEART® | REFRIGERATION  
SIMPLE OPERATION AND MAINTENANCE

## Hoshizaki's Warranty

- ▶ 5 Year Warranty on Labor for the entire machine
- ▶ 6 Year Warranty on Parts for the entire machine
- ▶ 7 Year Warranty on Parts for the Compressor

QR Code on the back of each unit for easy access to warranty and service information



Ask About Our **NEW**  
Worry-Free Warranty!

<b>FIVE</b> years <b>LABOR</b>	<b>SIX</b> years <b>PARTS</b>	<b>SEVEN</b> years <b>COMPRESSOR</b>
-----------------------------------	----------------------------------	---

**HOSHIZAKI**

## Our Commitment to Customers

Our commitment to quality continues after the sale. To ensure your HOSHIZAKI equipment operates at its optimum, we provide the following:

- ▶ An established field service network
- ▶ Toll-Free Technical Support Line 24 hours, 7 days a week, including holidays - **800-233-1940**
- ▶ Multi-level training - [www.hoshizakiamerica.com/training](http://www.hoshizakiamerica.com/training)







**Peachtree City, GA**  
Corporate Headquarters & Manufacturing

**HOSHIZAKI** is a global leader in the design, manufacturing, and marketing of equipment for the foodservice industry. With their corporate office located in Peachtree City, Georgia, HOSHIZAKI produces the highest level of excellence in ice machines and refrigeration equipment. Delivering continuous innovation, durability and style, the HOSHIZAKI name is synonymous with reliability and customer commitment.



**Griffin, GA**  
Manufacturing



# HOSHIZAKI

## **HOSHIZAKI AMERICA, INC.**

618 Highway 74 South, Peachtree City, GA 30269

Toll Free: (800) 438-6087 | Fax: (800) 345-1325

[hoshizakiamerica.com](http://hoshizakiamerica.com)

08/28/23 Item #40098

