



COMBI CK-48V

2 in 1: high capacity vegetable cutter (1,300 lbs./h) + cutter with 8 liter bowl



DYNAMIC PREPARATION
FOOD PROCESSOR / VEG PREP COMBI MACHINES



SALES DESCRIPTION

It has a variable speed motor block, large-capacity head and 8 l cutter bowl equipped with a rotor with micro-serrated blades.
"Brushless" technology.

Equipped with "brushless" technology: powerful and efficient motors.

- ✓ Maximum efficiency: maintain the torque throughout the speed range.
- ✓ Exclusive "force control system": guarantee of a uniform and high quality result.
- ✓ Lightweight and compact design: they weigh less, they occupy less space.
- ✓ Improved air/water-tightness since no ventilation is required.
- ✓ They generate less noise: improved workplace environment.

Cutting function: a perfect cut

- ✓ High precision settings and comprehensive cutter and disc design aimed at obtaining a perfect cut.
- ✓ It can be fitted with a wide range of discs and grids of the highest cutting quality. Combining these accessories together to obtain more than 70 different types of cuts and grating grades.
- ✓ Exclusive "Force Control System" to optimise and standardise the cutting of each product: acoustic warning when the motor exceeds the pre-established force.

Cutter function: efficiency and performance

- ✓ Possibility of programming by time and pulse button.
- ✓ Reverse function, ideal for mixing products instead of cutting.
- ✓ 8 litre stainless steel bowl.
- ✓ Polycarbonate lid with built-in "cut&mix" mixer.
- ✓ Depending on the purpose, the possibility of using optional smooth or perforated blades.

Built to last

- ✓ Made from stainless steel and food-grade materials of the highest quality: stainless steel motor block and food-grade aluminium head. Stainless steel bowl with highly-resistant polycarbonate lid.

Maximum comfort for the user

- ✓ Ergonomic design. Maximum comfort for the user.
- ✓ Lateral product output: it requires less room on the work surface and directs the product avoiding splashing.
- ✓ Advanced control panel that is very intuitive to use and offers all the information at a glance.

Maintenance, safety, hygiene

- ✓ Plunger, lid and hopper easy to remove for changing or cleaning.
- ✓ Combination of security systems: head, covers, bowl, power switch.
- ✓ Appliance certified by NSF International (regulations on hygiene, cleaning and materials suitable for contact with foods).
- ✓ 100% tested.

INCLUDES

- ✓ Variable speed motor block.
- ✓ Large capacity head.
- ✓ Cutter bowl, with micro-serrated blade rotor.

OPTIONAL

- Tube head.
- High production semi-automatic bowl.
- Discs, grids and disc support.
- Rotor with smooth cutting blades.
- Rotor with perforated cutting blades.
- Support-trolley.
- Grid cleaning kit.

ACCESSORIES

- FCC curved slicing discs
- FCO rippled slicing discs
- FFC chipping grids
- FMC dicing grids
- FCE julienne discs
- FR shredding & grating discs
- Disc and grid packs
- Disc and grid holder
- Blades for CK / K / KE
- Grid cleaning kit
- FC-D slicing discs
- SH shredding & grating discs

SPECIFICATIONS

Total loading: 3 Hp

As vegetable preparation machine

Hourly production: 400 lb - 1300 lb
 Inlet opening: 44.4 in²
 Disc diameter: 8"
 Speed as veg. slicer: 300 rpm - 1000 rpm
 External dimensions (W x D x H): 15.4" x 15.7" x 25.7"
 Net weight: 67.9 lb

As cutter

Bowl capacity: 8.5 qt
 Speeds as cutter (positions): 300 rpm - 3000 rpm
 External dimensions (W x D x H): 11.3" x 15.2" x 20.4"
 Net weight (Cutter): 41.9 lb
 Noise level (1m.): <70 dB(A)
 Background noise: 32 dB(A)

Crated dimensions

[n:embalaje_ancha] x [n:embalaje_fondo] x [n:embalaje_alto] [m:embalaje_ancha]





COMBI CK-48V

2 in 1: high capacity vegetable cutter (1,300 lbs./h) + cutter with 8 liter bowl



Volume Packed: 0.15 m³
Gross weight: 79.6 lbs.

AVAILABLE MODELS

1050821 Combi vegetable prep.-cutter CK-48V 230/50-60/1

1050822 Combi vegetable prep.-cutter CK-48V 120/50-60/1

* Ask for special versions availability

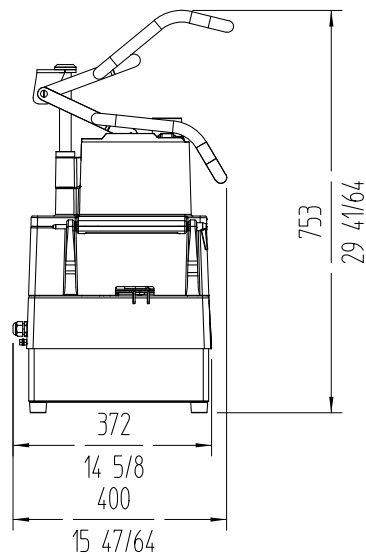
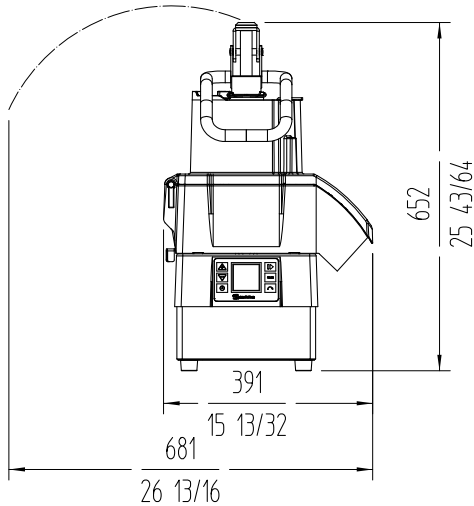
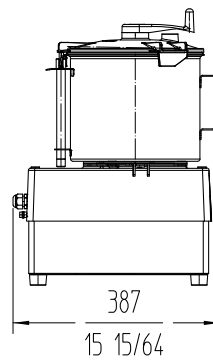
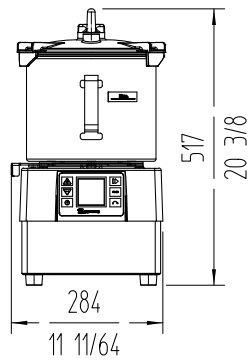

sammic | www.sammic.us
Food Service Equipment Manufacturer

usa@sammic.com
1225 Hartrey Avenue
60202-1056 Evanston, IL

phone +1 (224) 307-2232
toll free +1 844 275 3848



Project	Date
Item	Qty
Approved	

product sheet
updated 11/28/23

DYNAMIC PREPARATION
FOOD PROCESSOR / VEG PREP COMBI MACHINES